

What Doesn't Work

- Deniers are a fringe group ... **ignore them**
- **Data deluge** -
bury the audience with graphs, numbers
- Argument from **authority**:
credentials, consensus
- Messages of **fear**, alarm
- Point-by-point refutation of **details**

Across Partisan Lines, Fewer See Solid Evidence of Global Warming

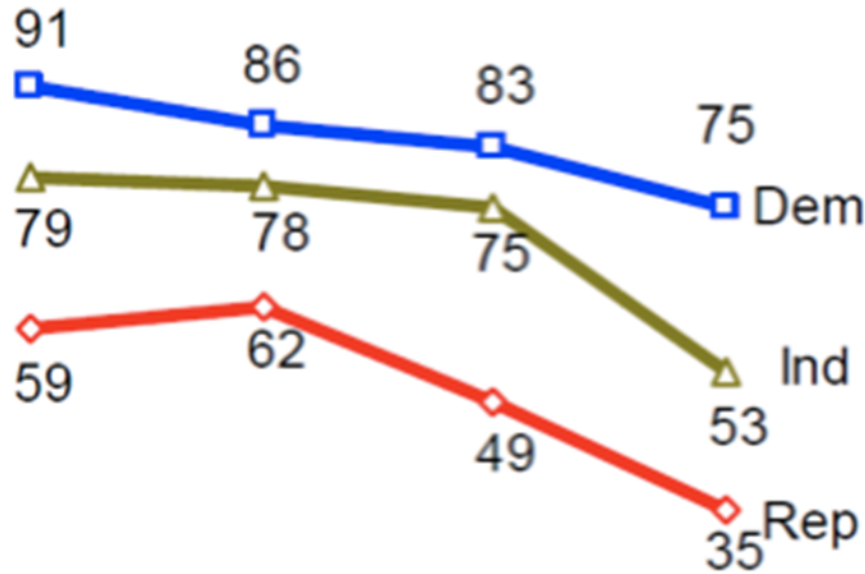

Changing Public Opinions

What Works Better

- Emphasize the **basics** -
 - argue from common sense, not from authority
- Recognize that opposition is **ideological**
 - (not scientific) -> Ideas deserve **respect**.
- Be **human**
 - Personal anecdotes, humor, a light touch
- Be **optimistic**
 - Don't sell doom and gloom
- ***Stick to your message*** -
 - don't get sucked off into the weeds

Global Warming is Based on Common Sense

not computer models ...
not recent temperatures ...
not complicated!

Ever Wonder Why?



- **Day** is warmer than **night**
- **Summer** is warmer than **winter**
- **Miami** is warmer than **Minneapolis**

Heat Budgets

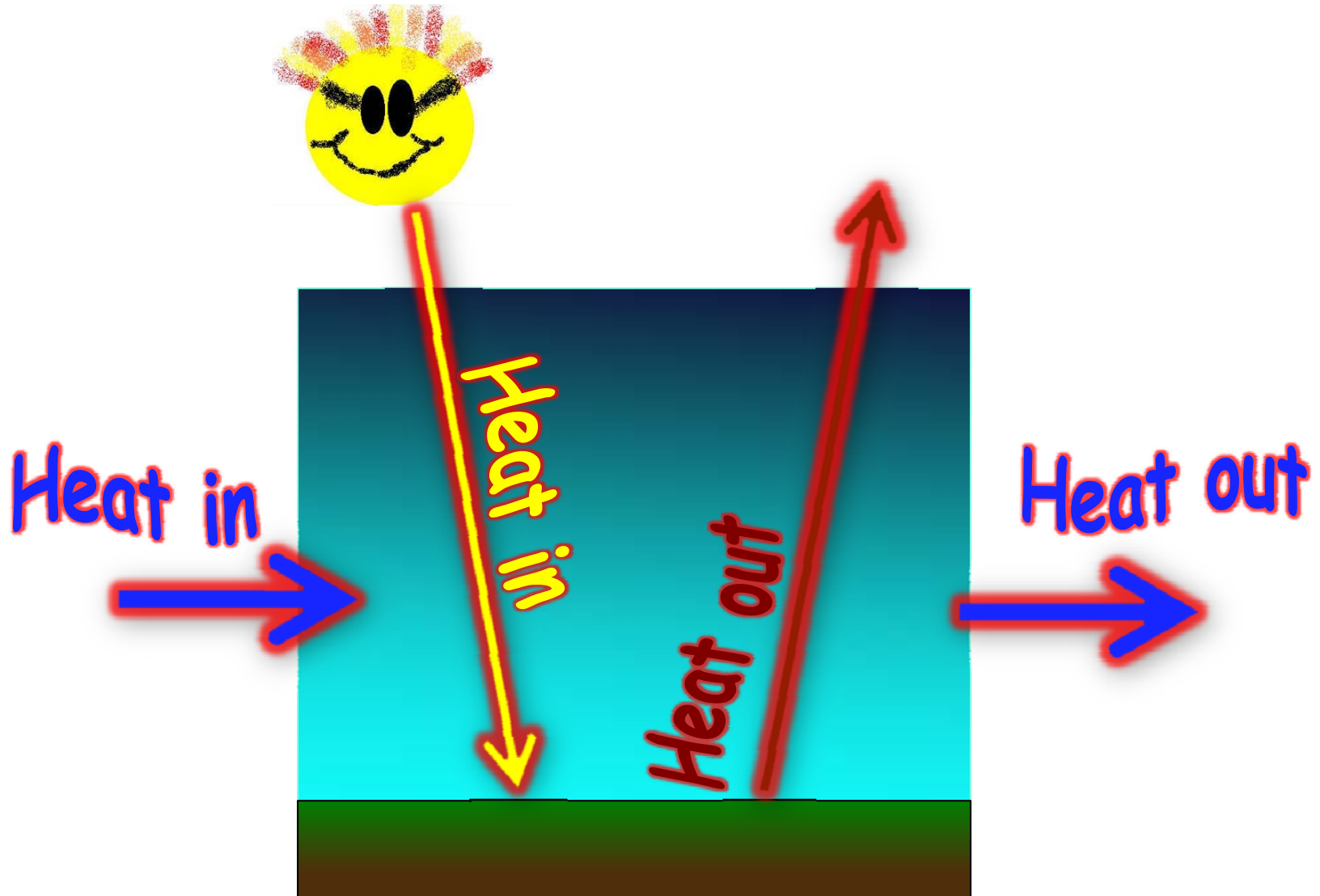

Dancing Molecules and Heat Rays!

- Nearly all of the air is made of oxygen (O_2) and nitrogen (N_2) in which **two atoms of the same element** share electrons
- Infrared (heat) **energy radiated up from the surface can be absorbed** by these molecules, but not very well

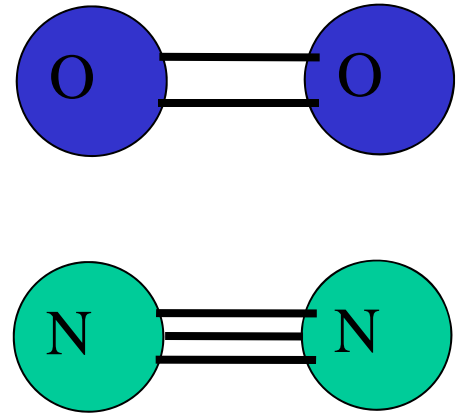

Diatomic molecules can vibrate back and forth like balls on a spring, but the ends are identical

Dancing Molecules and Heat Rays!

- Carbon dioxide (CO_2) and water vapor (H_2O) are different!
- They have **many more ways to vibrate** and rotate, so they are very good at absorbing and emitting infrared (heat) radiation

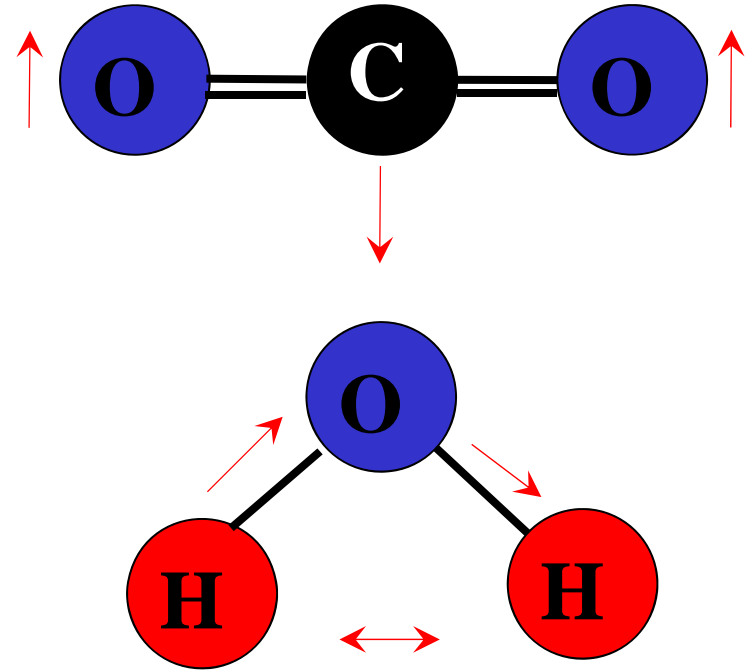

Molecules that have many ways to wiggle are called “Greenhouse” molecules

Absorption spectrum of CO_2 was measured by John Tyndall in 1863

Common Sense

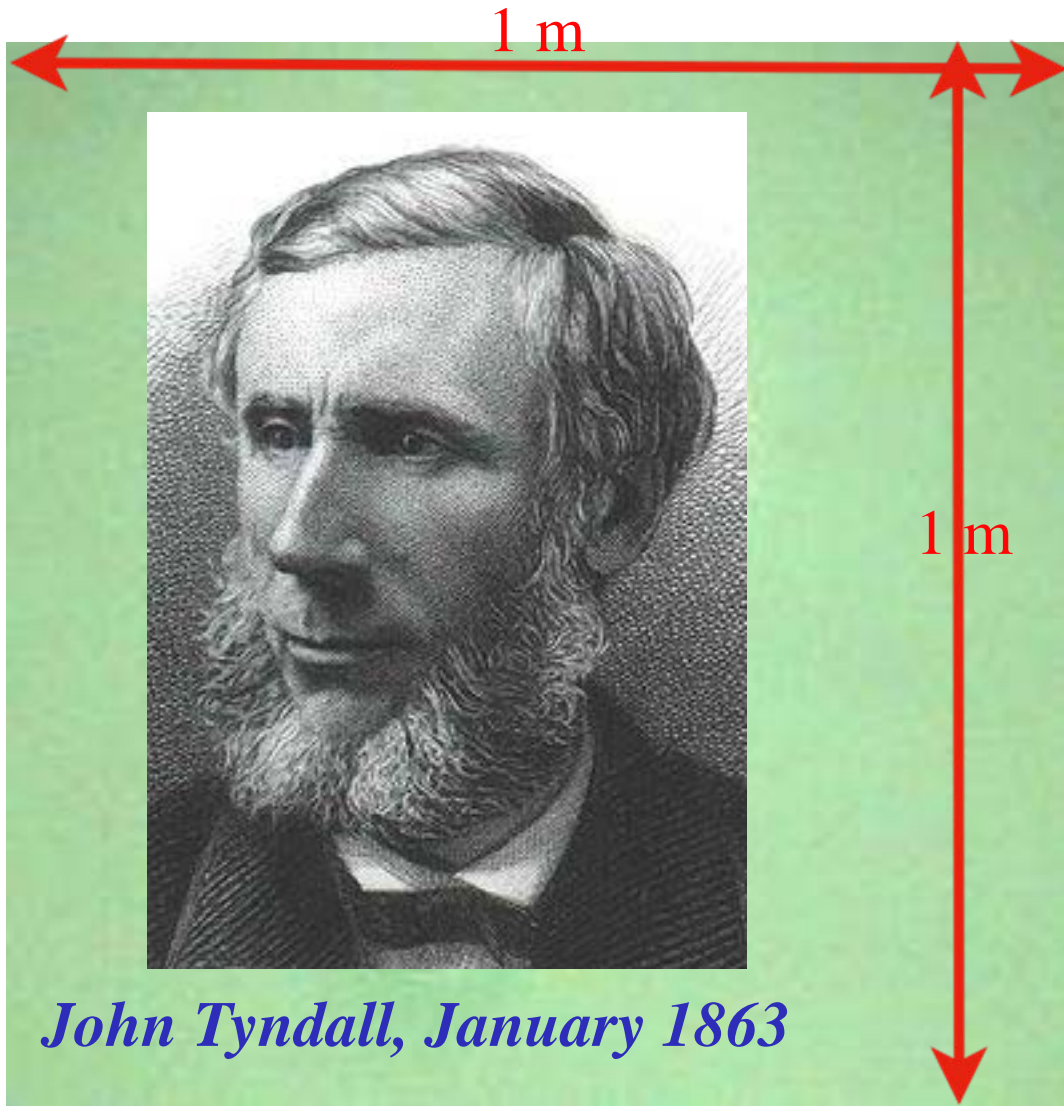

- Doubling CO_2 would add **4 watts** to **every square meter** of the surface of the Earth, **24/7**
- Doing that would make the surface **warmer**
- This was known before light bulbs were invented!

A Common Myth

"Scientists are worried about climate change because it's been warming up recently"

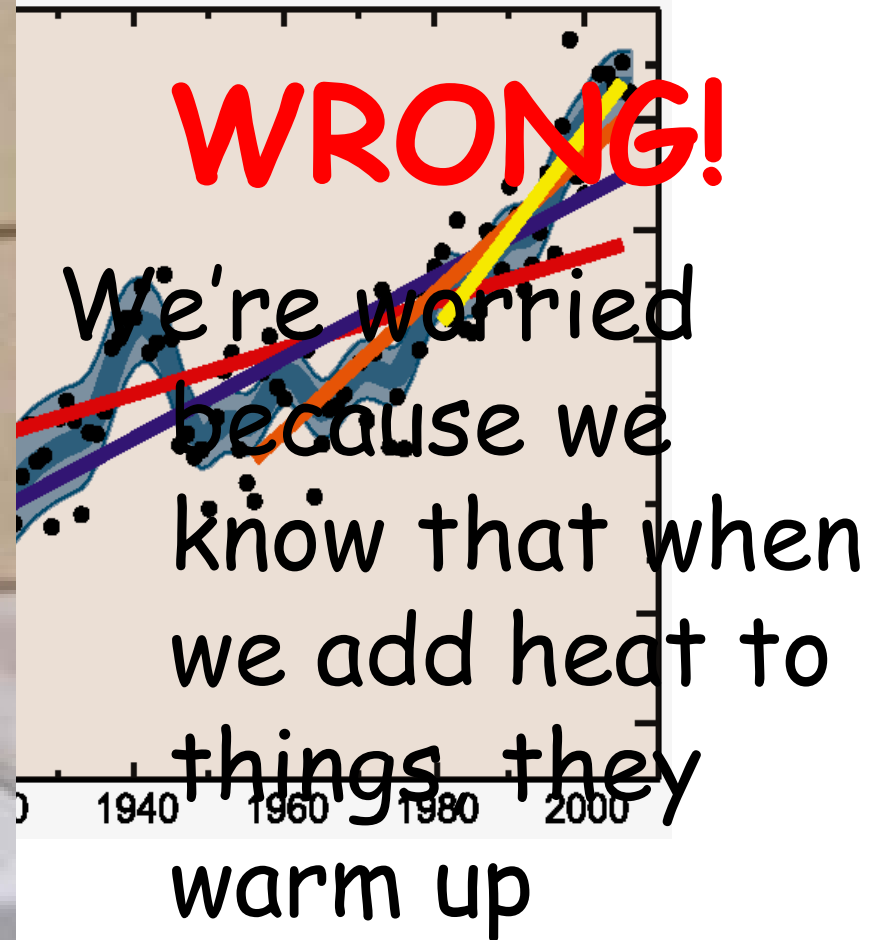

The Worst Myth of All

- Without the subsidy of cheap fossil energy, civilization will crumble!
- People will freeze in the dark!
- They'll starve!

"The sky is falling!"

Be skeptical ... be very skeptical !

Solutions

- To provide a **decent standard of living** for billions of people on Earth
- We must be able to generate huge amounts of **energy without releasing CO₂**
- This is **definitely do-able** (as an engineering task) ...
- but expensive and **politically difficult**
- Can't do it by "tinkering around the edges"
- Requires **profound change to energy and economics**

Imagine it's 1800, and you're in charge ...

Somebody presents you with a grand idea for transforming the world economy:

- ✓ Dig 8 billion holes 1 foot deep every year
- ✓ Build a system of canals, railroads, highways, and pipelines to deliver it to every street corner
- ✓ Build millions of miles of roads, bridges, and millions of houses
- ✓ Generate and pipe enough electricity to every house to power lights & stereos & plasma TVs



... *"and here's the itemized bill ..."*

Choose Your Future

- Some people think:
 - "Our modern lifestyle is only possible because of the subsidy of cheap fossil fuel. If we stop burning coal we'll freeze in the dark!"
- I prefer:
 - "Our well-being depends on creativity and hard work. Before we run out of oil, we'll invent energy technologies for the 21st Century.
 - **Our future is bright."**